

## LD Series Oil and Grease Pump

3A1334F  
EN

For dispensing non-corrosive and non-abrasive lubricants, oil, grease, and automatic transmission fluids in stationary or mobile installations. Use with compressed air only. For professional use only. Not for use with windshield washer fluid.

List of models, including Maximum Fluid Pressure:

- Oil Pump Models: page 2
- Grease Pump Models: page 3



### Important Safety Instructions

Read all warnings and instructions in this manual. Save these instructions.

### Related Translated Manuals

Manual Number	Language
3A1339	Spanish
3A1345	French
3A1350	German
3A1360	Russian
3A1365	Chinese
3A1370	Japanese
3A1375	Korean

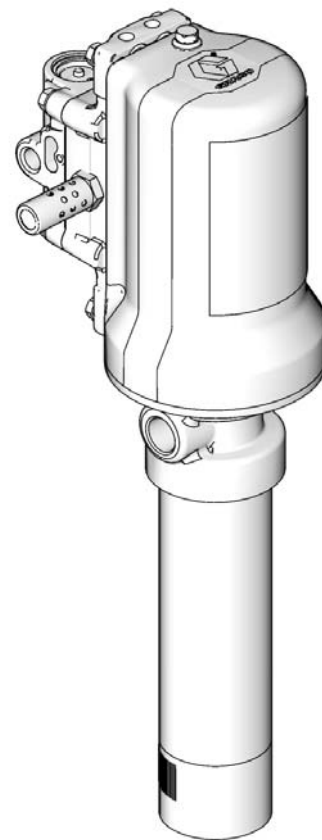

# Oil Pump Models

All oil models include a 2" npt(m) bung adapter.

PN	Description	Max air pressure			Max Fluid Pressure			Air inlet	Fluid Inlet	Fluid Outlet
		psi	Mpa	bar	psi	Mpa	bar			
<b>3:1 PUMPS</b>										
24G576	Universal	150	1.03	10.3	750	5.17	51.7	1/4"-18 NPT	1"-11.5 NPT	1/2"-14 NPT
24G577	Universal	150	1.03	10.3	750	5.17	51.7	1/4"-19 BSPP	1-11 BSPP	1/2"-14 BSPP
24G578	Universal	150	1.03	10.3	750	5.17	51.7	1/4"-19 BSPT	1-11 BSPT	1/2"-14 BSPT
24G579*	Multilength	150	1.03	10.3	750	5.17	51.7	1/4"-18 NPT	1"-11.5 NPT	1/2"-14 NPT
24G580*	Multilength	150	1.03	10.3	750	5.17	51.7	1/4"-19 BSPP	1-11 BSPP	1/2"-14 BSPP
24G581*	Multilength	150	1.03	10.3	750	5.17	51.7	1/4"-19 BSPT	1-11 BSPT	1/2"-14 BSPT
24G582*	200L (55gal) drum	150	1.03	10.3	750	5.17	51.7	1/4"-18 NPT	1"-11.5 NPT	1/2"-14 NPT
24G583*	200L (55gal) drum	150	1.03	10.3	750	5.17	51.7	1/4"-19 BSPP	1-11 BSPP	1/2"-14 BSPP
24G584*	200L (55gal) drum	150	1.03	10.3	750	5.17	51.7	1/4"-19 BSPT	1-11 BSPT	1/2"-14 BSPT
24G585*	1040 liter (275gal) tote	150	1.03	10.3	750	5.17	51.7	1/4"-18 NPT	1"-11.5 NPT	1/2"-14 NPT
24G586*	1040 liter (275gal) tote	150	1.03	10.3	750	5.17	51.7	1/4"-19 BSPP	1-11 BSPP	1/2"-14 BSPP
24G587*	1040 liter (275gal) tote	150	1.03	10.3	750	5.17	51.7	1/4"-19 BSPT	1-11 BSPT	1/2"-14 BSPT
<b>5:1 PUMPS</b>										
24G588	Universal	150	1.03	10.3	750	5.17	51.7	1/4"-18 NPT	1"-11.5 NPT	1/2"-14 NPT
24G589	Universal	150	1.03	10.3	750	5.17	51.7	1/4"-19 BSPP	1-11 BSPP	1/2"-14 BSPP
24G590	Universal	150	1.03	10.3	750	5.17	51.7	1/4"-19 BSPT	1-11 BSPT	1/2"-14 BSPT
24G591*	5:1 Multilength	150	1.03	10.3	750	5.17	51.7	1/4"-18 NPT	1"-11.5 NPT	1/2"-14 NPT
24G592*	5:1 Multilength	150	1.03	10.3	750	5.17	51.7	1/4"-19 BSPP	1-11 BSPP	1/2"-14 BSPP
24G593*	5:1 Multilength	150	1.03	10.3	750	5.17	51.7	1/4"-19 BSPT	1-11 BSPT	1/2"-14 BSPT
24G594*	200L (55gal) drum	150	1.03	10.3	750	5.17	51.7	1/4"-18 NPT	1"-11.5 NPT	1/2"-14 NPT
24G595*	200L (55gal) drum	150	1.03	10.3	750	5.17	51.7	1/4"-19 BSPP	1-11 BSPP	1/2"-14 BSPP
24G596*	200L (55gal) drum	150	1.03	10.3	750	5.17	51.7	1/4"-19 BSPT	1-11 BSPT	1/2"-14 BSPT
24G597*	1040 liter (275gal) tote	150	1.03	10.3	750	5.17	51.7	1/4"-18 NPT	1"-11.5 NPT	1/2"-14 NPT
24G598*	1040 liter (275gal) tote	150	1.03	10.3	750	5.17	51.7	1/4"-19 BSPP	1-11 BSPP	1/2"-14 BSPP
24G599*	1040 liter (275gal) tote	150	1.03	10.3	750	5.17	51.7	1/4"-19 BSPT	1-11 BSPT	1/2"-14 BSPT



\* Includes universal pump and down tube, packaged separately.





# Grease Pump Models

PN	Description	Max air pressure			Max Fluid Pressure			Air inlet	Fluid Inlet	Fluid Outlet
		psi	Mpa	bar	psi	Mpa	bar			
<b>50:1 PUMPS</b>										
24G600	16kg (35lb)	150	1.03	10.3	7500	51.7	517	1/4"-18 Npt	Priming piston	1/4"-18 Npt
24G601	16kg (35lb)	150	1.03	10.3	7500	51.7	517	1/4"-19 BSPP	Priming piston	1/4"-19 BSPP
24G602	16kg (35lb)	150	1.03	10.3	7500	51.7	517	1/4"-19 BSPT	Priming piston	1/4"-19 BSPT
24G603	55kg (120lb)	150	1.03	10.3	7500	51.7	517	1/4"-18 Npt	Priming piston	1/4"-18 Npt
24G604	55kg (120lb)	150	1.03	10.3	7500	51.7	517	1/4"-19 BSPP	Priming piston	1/4"-19 BSPP
24G605	55kg (120lb)	150	1.03	10.3	7500	51.7	517	1/4"-19 BSPT	Priming piston	1/4"-19 BSPT
24G606	180kg (400lb)	150	1.03	10.3	7500	51.7	517	1/4"-18 Npt	Priming piston	1/4"-18 Npt
24G607	180kg (400lb)	150	1.03	10.3	7500	51.7	517	1/4"-19 BSPP	Priming piston	1/4"-19 BSPP
24G608	180kg (400lb)	150	1.03	10.3	7500	51.7	517	1/4"-19 BSPT	Priming piston	1/4"-19 BSPT

# Warnings

The following warnings are for the setup, use, grounding, maintenance, and repair of this equipment. The exclamation point symbol alerts you to a general warning and the hazard symbols refer to procedure-specific risks. When these symbols appear in the body of this manual, refer back to these Warnings. Product-specific hazard symbols and warnings not covered in this section may appear throughout the body of this manual where applicable.



 <b>WARNING</b>	
	<p><b>SKIN INJECTION HAZARD</b></p> <p>High-pressure fluid from dispense valve, hose leaks, or ruptured components will pierce skin. This may look like just a cut, but it is a serious injury that can result in amputation. <b>Get immediate surgical treatment.</b></p> <ul style="list-style-type: none"> <li>• Do not point dispense valve at anyone or at any part of the body.</li> <li>• Do not put your hand over the end of the dispense nozzle.</li> <li>• Do not stop or deflect leaks with your hand, body, glove, or rag.</li> <li>• Follow <b>Pressure Relief Procedure</b> in this manual, when you stop spraying and before cleaning, checking, or servicing equipment.</li> <li>• Tighten all fluid connections before operating the equipment.</li> <li>• Check hoses and couplings daily. Replace worn or damaged parts immediately.</li> </ul>
	<p><b>FIRE AND EXPLOSION HAZARD</b></p> <p>When flammable fluids are present in the work area, such as gasoline and windshield wiper fluid, be aware that flammable fumes can ignite or explode. To help prevent fire and explosion:</p> <ul style="list-style-type: none"> <li>• Use equipment only in well ventilated area.</li> <li>• Eliminate all ignition sources, such as cigarettes and portable electric lamps.</li> <li>• Keep work area free of debris, including rags and spilled or open containers of solvent and gasoline.</li> <li>• Do not plug or unplug power cords or turn lights on or off when flammable fumes are present.</li> <li>• Ground all equipment in the work area.</li> <li>• Use only grounded hoses.</li> <li>• If there is static sparking or you feel a shock, <b>stop operation immediately.</b> Do not use equipment until you identify and correct the problem.</li> <li>• Keep a working fire extinguisher in the work area.</li> </ul>

 <b>WARNING</b>	
	<p><b>EQUIPMENT MISUSE HAZARD</b></p> <p>Misuse can cause death or serious injury.</p> <ul style="list-style-type: none"> <li>• Do not operate the unit when fatigued or under the influence of drugs or alcohol.</li> <li>• Do not exceed the maximum working pressure or temperature rating of the lowest rated system component. See <b>Technical Data</b> in all equipment manuals.</li> <li>• Use fluids and solvents that are compatible with equipment wetted parts. See <b>Technical Data</b> in all equipment manuals. Read fluid and solvent manufacturer's warnings. For complete information about your material, request MSDS forms from distributor or retailer.</li> <li>• Check equipment daily. Repair or replace worn or damaged parts immediately with genuine manufacturer's replacement parts only.</li> <li>• Do not alter or modify equipment.</li> <li>• Use equipment only for its intended purpose. Call your distributor for information.</li> <li>• Route hoses and cables away from traffic areas, sharp edges, moving parts, and hot surfaces.</li> <li>• Do not kink or over bend hoses or use hoses to pull equipment.</li> <li>• Keep children and animals away from work area.</li> <li>• Comply with all applicable safety regulations.</li> </ul>
	<p><b>PRESSURIZED ALUMINUM PARTS HAZARD</b></p> <p>Use of fluids that are incompatible with aluminum in pressurized equipment can cause serious chemical reaction and equipment rupture. Failure to follow this warning can result in death, serious injury, or property damage.</p> <ul style="list-style-type: none"> <li>• Do not use 1,1,1-trichloroethane, methylene chloride, other halogenated hydrocarbon solvents or fluids containing such solvents.</li> <li>• Many other fluids may contain chemicals that can react with aluminum. Contact your material supplier for compatibility.</li> </ul>
	<p><b>PERSONAL PROTECTIVE EQUIPMENT</b></p> <p>You must wear appropriate protective equipment when operating, servicing, or when in the operating area of the equipment to help protect you from serious injury, including eye injury, hearing loss, inhalation of toxic fumes, and burns. This equipment includes but is not limited to:</p> <ul style="list-style-type: none"> <li>• Protective eyewear, and hearing protection.</li> <li>• Respirators, protective clothing, and gloves as recommended by the fluid and solvent manufacturer.</li> </ul>

# Installation

**NOTE:** Reference letters and numbers in parentheses in the text refer to callouts in the figures and drawings.

## Grounding

						
<p>To reduce the risk of static sparking, ground the pump and all other components used or located in the dispensing area. Check your local electrical code for detailed instructions for your area and type of equipment.</p>						

### Ground all equipment:

- *Pump:* Use a ground wire and clamp as shown in FIG. 1.
  - a. Remove the ground screw (Z) and insert through the eye of the ring terminal at end of ground wire (Y).
  - b. Fasten the ground screw back onto the pump and tighten securely.

**NOTE:** To order a ground wire and clamp, order Graco Part No. 222011.

- *Air and fluid hoses:* Use only electrically conductive hoses.
- *Air compressor:* Follow manufacturer's recommendations.
- *Dispensing valve:* Ground through connection to a properly grounded fluid hose and pump.
- *Object being dispensed to:* Follow your local code.
- *Solvent pails used when flushing:* Follow your local code. Use only metal pails, which are conductive, placed on a grounded surface. Do not place the pail on a nonconductive surface, such as paper or cardboard, which interrupts the grounding continuity.
- *To maintain grounding continuity when flushing or relieving pressure,* hold a metal part of the dispensing valve firmly to the side of a grounded metal pail, then trigger the dispense valve.

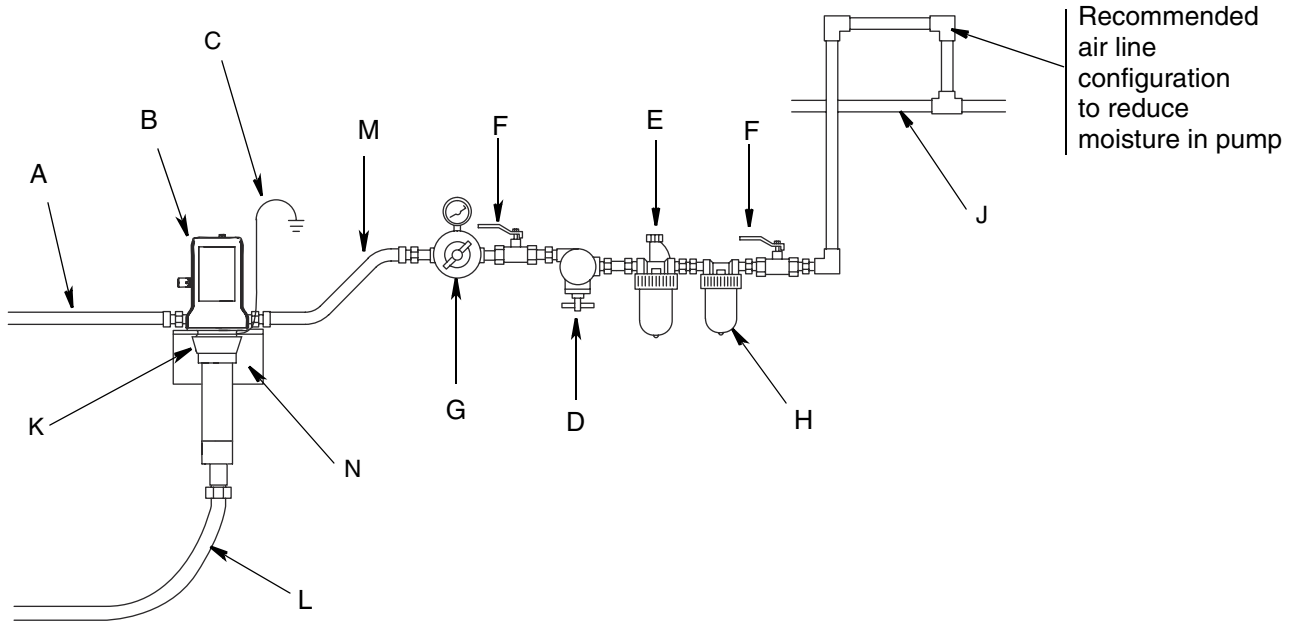

**FIG. 1**

## Typical Installation

The typical installation shown in FIG. 2 is only an installation guide. It is not an actual system design. Contact your Graco Distributor for assistance in designing a system to suit your needs.

### Stationary Mountings



ti16120

FIG. 2

#### Key (FIG. 2)





- A Fluid outlet line (flexible connection required)
- B Pump
- C Ground wire
- D Pump runaway valve
- E Air lubricator
- F Bleed-type master air valve (required)
  - NPT - Part No. 110223
  - BSP - Part No. 125272
- G Air regulator (self-relieving regulator required)
  - NPT - Part No. 24H420
  - BSP - Part No. 24H419
- H Air filter
- J Main air line
- K Bung adapter - Part No. 24F918
- L Fluid inlet line (flexible connection required)
- M Air inlet line (flexible connection required)
- N Wall mount bracket - Part No. 24F910

## Installation Guidelines

Reference letters found in the following instructions, refer to *Typical Installation diagram provided on page 7*.

- A ball valve must be installed upstream of the regulator (G).
- The fluid outlet line (A), fluid inlet line (L) and air inlet line (M) must be flexible (such as a hose).

**NOTE:** To prevent damage to the pump, remove sediment from the bottom of the container before installing a pump on an existing container.

						
<p>The maximum working pressure of each pump in your system may not be the same. To reduce the risk of over-pressurizing any part of your system, which may result in component rupture, fire or explosion and cause serious bodily injury, be sure you know the maximum working pressure rating of each pump and its connected components.</p> <ul style="list-style-type: none"> <li>• <b>Never</b> exceed the maximum working pressure of the lowest rated component connected to a particular pump.</li> <li>• Be sure you know the maximum working pressure of each component.</li> <li>• Do not exceed the maximum pump cycle rate.</li> <li>• Regulate air pressure to prevent over pressurization at fluid section of the pump.</li> <li>• Regulate air pressure to the pump so that no fluid line component or accessory is over pressurized.</li> </ul>						

## Stationary Mounting Layout

Plan the layout for easy operator access to the pump air controls, sufficient room to change drums and a secure platform.

## Pump Mounting

1. Install bung adapter (K) into bung mount/bracket/or drum cover.
2. Install pump (B) into bung adapter (K).

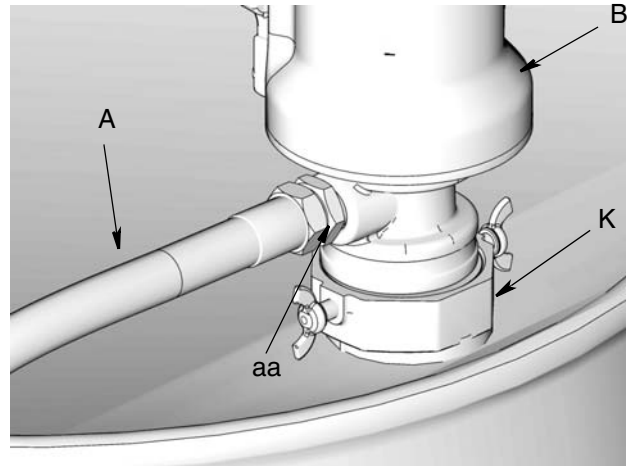

**FIG. 3**

### Installing Outlet Hose (FIG. 3)

1. Connect the swivel adapter (aa) to the pump fluid outlet. Tighten securely and torque as recommended below:
  - For NPT models: 1 to 1-1/2 turns past hand tight.
  - For BSPT models: 1-1/2 to 2 turns past hand tight.
2. Connect the fluid hose (A) to the swivel adapter (aa).
3. Connect a suitable dispensing valve or extra hose to the 6-ft hose.



## Air Line and Accessories

NOTE: Install the air line accessories in the order shown in the Typical Installation on page 7.

### NOTICE

Do not hang the air accessories directly on the air inlet. Mount them on brackets. Always use a flexible hose between all connections. The air inlet is not strong enough to support accessories and may cause one or more to break.

- Use thread sealant on all male threads **except** swivel connections.
- Install a pump runaway valve (D) to shut off the air to the pump if the pump accelerates beyond the pre-adjusted setting. A pump that runs too fast can be seriously damaged.
- Install the air regulator (G) to control pump speed and pressure.

*For NPT models order Graco Part No. 24H420 or for BSP models order Graco Part No. 24H419.*

- Install a bleed-type master air valve (F) upstream from the pump air regulator (G) but within easy reach of the pump.

*For NPT models order Graco Part No. 110223 or for BSP models order Graco Part No. 125272.*

- On the main air supply line from the compressor, install an air line filter (H) to remove harmful dirt and contaminants from the compressor air supply.

## Follow Plate - Grease Models Only

For grease models only a follow plate is required for pumping fluid from the drum. See page 12 for follow plate installation instructions.

# Operation

## Thermal Induced Pressure Relief (Oil pumps only)

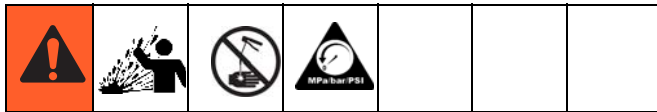

### THERMAL EXPANSION HAZARD

Fluids subjected to heat in confined spaces, including hoses, can create a rise in pressure due to the thermal expansion. Over-pressurization can result in equipment rupture and serious injury.

Oil pumps have a built-in, thermal induced, pressure relief as shown in FIG. 4. To ensure system pressure will automatically bleed excess thermal induced system pressure through the pump and back to the oil reservoir:

- Always use a relieving air pressure regulator to allow the pump/motor to run backwards. The regulator bleeds excess air pressure.
- There should not be any obstructions between air inlet of pump and regulator.
- There should not be any obstructions between the downstream plumbing and pump outlet such as closed ball valves or check valves.
- There should not be any obstructions between the pump inlet and fluid container such as closed ball valves or check valves.
- Only use Graco designed suction tubes for in-drum or in-tank applications.
- Only use Graco designed suction tubes with a built-in relief device for wall mount applications.
- Always use an inlet screen to prevent debris from plugging relief passages from entering the pump.
  - Do not operate the pump with out an inlet screen.
- Periodically inspect the inlet screen for plugging. Graco recommends inspecting the inlet screen every time the container is changed out.

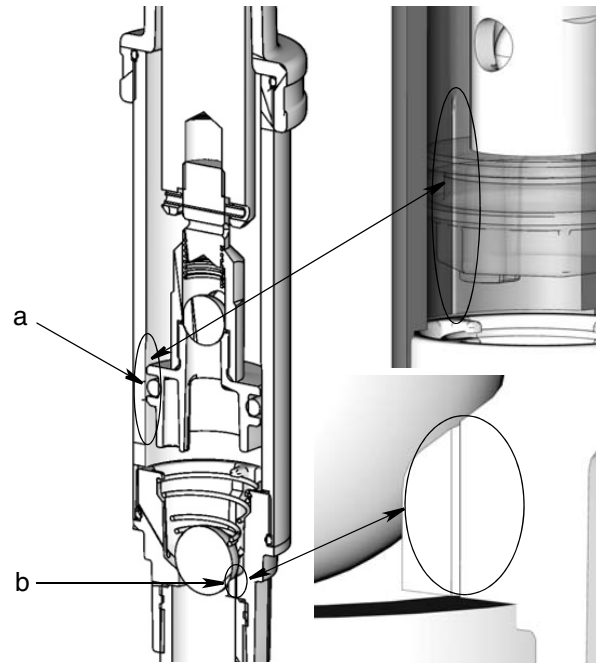

FIG. 4 a = Pump cylinder relief passage  
b = Inlet check relief passage

### Thermal Relief Theory of Operation

The pump operation is similar to most double acting reciprocating pumps. The pump only comes to a complete stop on the up stroke. The pump will stroke through on the down stroke due to the inlet check relief passage.

Excess pressure due to downstream thermal expansion causes the air motor/pump to run backwards (downward). Fluid pressure is relieved through the inlet check relief passage as the pump piston moves downward. Air pressure is simultaneously relieved through the air inlet passage. The pump piston moves downward exposing the pump cylinder relief passage at the bottom of the stroke. Additional excess pressure is then relieved through both the inlet check relief passage and the pump cylinder relief passage.

Pressure is relieved at the pump through the pump inlet relief passage. The pump will not change over on the bottom of the stroke as a result of relieving excess pressure due to the positioning of the pump cylinder groove with respect to the air motor pilot valve.

#### NOTE:

- The air supply does not have to be turned off to enable thermal relief activation.
- The Thermal Induced Pressure Relief design feature of the pump will cause the pump to dive on the downstroke when a dispensing valve is closed.



Install only one pump per delivery system. Do not use the pumps in a parallel pump installation.

Loss of pump prime can occur if all the following events occur in sequence:

1. A thermal relief event occurs.
2. The air supply valve is closed.
3. A dispense valve located at an elevation higher than the tank level, is open.

To prevent loss of prime, ensure the air supply valve is turned on before attempting to dispense fluid.

## Pressure Relief Procedure

						
<p>The equipment stays pressurized until pressure is manually relieved. To reduce the risk of serious injury from pressurized fluid, fluid from the valve, or splashing fluid, follow this procedure whenever you:</p> <ul style="list-style-type: none"> <li>• are instructed to relieve pressure</li> <li>• stop dispensing</li> <li>• check, clean, or service any system equipment</li> <li>• install or clean dispensing devices.</li> </ul>						

1. Close the pump's bleed-type master air valve.
2. Close the pump air regulator and disconnect the air supply hose.
3. Open the dispensing valve and dispense fluid into a waste bucket/container until pressure is fully relieved.

*If you suspect that the dispensing valve is clogged, or that pressure has not been fully relieved after following the steps above, **very slowly** loosen the dispensing valve coupler or hose end coupling to relieve pressure gradually, then loosen completely.*

## Start-up

### Determining Output Pressure Using the Air Regulator

To determine the fluid output pressure using the air regulator reading, multiply the ratio of the pump by the air pressure shown on the regulator.

For example a 3:1 ratio oil pump:

$$3:1 \text{ ratio} \times 100 \text{ psi air} = 300 \text{ psi fluid outlet}$$

A 3:1 pump is capable of 5:1 on the downstroke and will develop 5:1 pressures under normal operation.

A grease pump has a ratio of 50:1. However it is capable of reaching a stall pressure equal to 60 times the air input pressure. To calculate the fluid output pressure using the air regulator reading, multiply the regulator gauge by 60.

For example:

$$140 \text{ psi air} \times 60 = 8400 \text{ psi fluid output}$$

$$0.97 \text{ MPa air} \times 60 = 58.2 \text{ MPa}$$

$$99.7 \text{ bar} \times 60 = 5982 \text{ bar}$$

Regulate air to the pump so that no air line or fluid line component or accessory is over pressurized.

### Priming the pump

1. Close the air regulators and bleed-type master air valves to all but one pump.
2. Open the master air valve from the compressor.
3. For the pump that is connected, trigger the dispensing valve into a grounded metal waste container making firm, metal-to-metal contact between the container and the valve.
4. Slowly open the bleed-type master air valve and open the pump air regulator just until the pump is running. When the pump is primed and all air has been pushed out of the lines, release the trigger.
5. If you have more than one pump, repeat this process for each pump in your system.

NOTE: When the pump is primed and has sufficient air supplied to it, it starts when the dispensing valve is open and shuts off when closed.

**Step 6 is for Oil Pumps Only:**

- The thermal relief feature of this oil pump can increase the amount of time needed to fully prime the pump when compared to pumps without a thermal relief feature. To minimize this effect, prime the pump **before** connecting it to an already primed distribution system.

**NOTICE**

Never allow the pump to run dry of the fluid being pumped. A dry pump will quickly accelerate to a high speed, possibly damaging itself. If your pump accelerates quickly, or is running too fast, stop it immediately and check the fluid supply. If the supply container is empty and air has been pumped into the lines, prime the pump and lines with fluid, or flush it and leave it filled with a compatible solvent. Be sure to eliminate all air from the fluid system.

**NOTE:** A pump runaway valve can be installed on the air line to automatically shut off the pump if it starts to run too fast.

- Read and follow the instructions supplied with each component in your system.
- When shutting off the system and before checking or servicing, relieve pressure following pressure relief procedure, page 10.

**Changing Grease Drum and Installing Follow Plate (grease models only)**



- Relieve pressure**, page 10.
- Remove drum cover by loosening thumb screws (a) (FIG. 5).

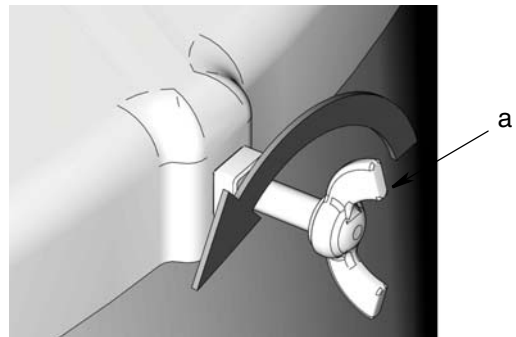

**FIG. 5**

- Remove pump and cover from drum and place on a clean paper, cardboard, or clean shop rags. **DO NOT PLACE ON SHOP FLOOR.**
- If this is an existing installation, reach into drum and pull on follow plate ring (b) to remove follow plate (FIG. 6). Place follow plate on a clean paper, cardboard or clean shop rags. **DO NOT PLACE ON SHOP FLOOR.**

Remove drum and install new one.

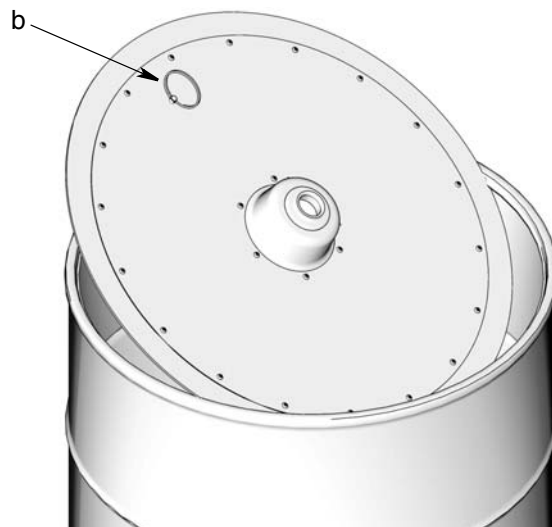

**FIG. 6**

5. Examine follow plate to make sure rubber grommet (c) is in place in center of the plate (FIG. 7).

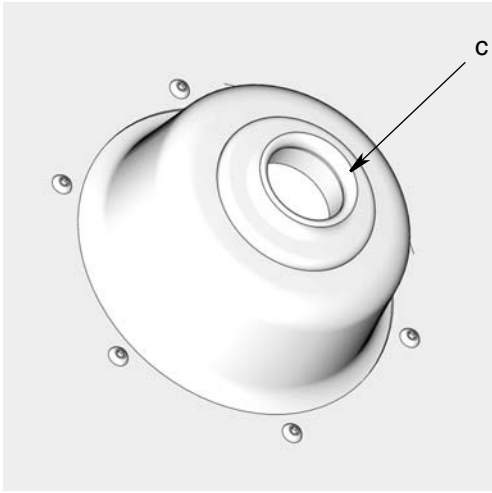

**FIG. 7**

6. Set follow plate on top of fresh grease (FIG. 8). Remove air by pushing on the follow plate until the grease level is flush with the opening in the middle of the follow plate (d).

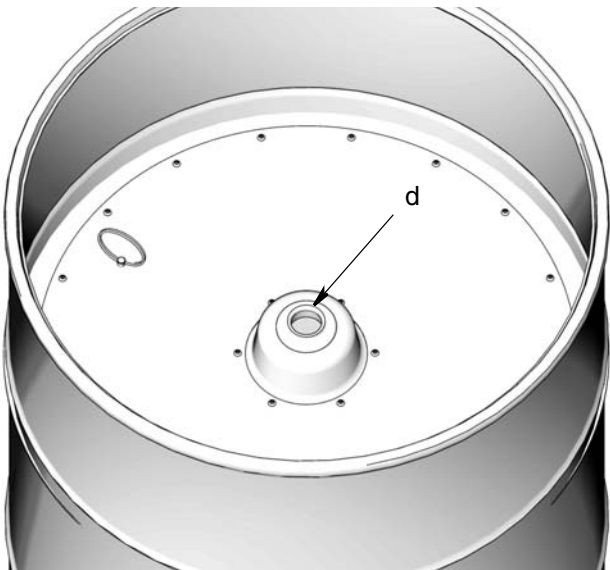

**FIG. 8**

7. Insert pump drop tube through center of rubber grommet in follow plate (FIG. 9).



**FIG. 9**

8. Tighten thumb screws (a) to secure cover to drum.

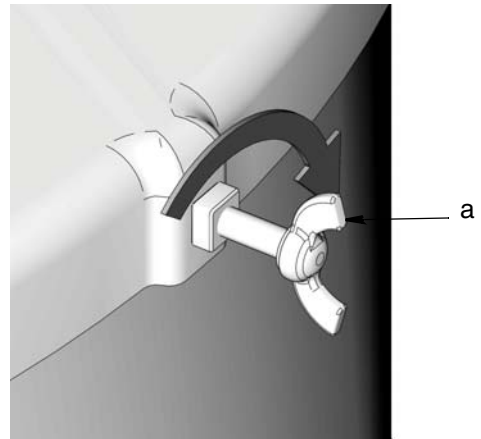

**FIG. 10**

9. For the pump that is connected, trigger the dispensing valve into a grounded metal waste container making firm, metal-to-metal contact between the container and the valve.
10. Slowly open the bleed-type master air valve and open the pump air regulator just until the pump is running. When the pump is primed and all air has been pushed out of the lines, release the trigger.

# Repair

## Replacing Pilot Valves

Reference letters shown in the following instructions refer to Typical Installation diagram, page 7. Part numbers refer to the Parts pages beginning on page 15.



1. Stop pump at the middle of its stroke.
2. Relieve pressure, page 11.
3. Disconnect the air line (M).
4. Use a 10 mm socket wrench to remove the old pilot valve (20).
5. Lubricate o-rings and install the new pilot valve (20). Torque to 95-105 in-lb (11-12 N.m).

# Parts

## 3:1 Oil Pump Models: 24G576 - 24G587: 5:1 Oil Pump Models: 24G588 - 24G599

Ref	Part No	Description	Qty
2	116343	SCREW, ground	1
3		SCREW	3
4		SCREW M6 x 22 mm	5
5	⊗	O-RING, air piston	1
6	⊗	O-RING	1
7	⊗	O-RING	1
8	⊗	O-RING,	1
9	⊗	SEAL, u-cup	1
10		PIN, spring	1
11	★	BALL, steel	1
12		BALL, steel	1
13	✓	O-RING, (models 24G576 - 24G578)	1
	✓	O-RING (models 24G588 - 24G590)	1
14	✓	O-RING	1
15	✓★	O-RING	1
16		SCREW	1
17	⊗	O-RING	3
18		BOLT M8 X 25	1
19		WASHER, M8 (not shown)	1
20	◆ ✕	VALVE, pilot	2
21		PISTON, air, plastic	1
22		BEARING, delrin	1
23	15M182 ❖ † ✕ ◆	SEAL, air valve, manifold (not shown)	1
24	15M213	MUFFLER, 3/8	1
	112933	MUFFLER, quiet (optional)	1
25	⊗	GASKET, cover, small	2
26		COVER, bottom, machining	1
27		CYLINDER air, machined	1
28	★	HOUSING, intake valve, machined	1
29		FLANGE, oil, machined	1
30		ROD, displacement	1
31		GUIDE, air	1
32		CYLINDER, fluid	1
33		PISTON, pump, 3:1, machining	1
34		HOLDER, ball	1
35	★	SPRING, compression	1
36		SPRING, compression	1
37		HOUSING, manifold, machined	1
38	✕	VALVE, air, small	1
39 ▲	16F541	LABEL, identification, ID 3:1	1

Ref	Part No	Description	Qty
40 ▲	16G243◆	LABEL, safety, warning, multiple	1
43	✕	SCREW, M6 x 25 mm	8
50	24F918	ADAPTER, bung, LD pump	1
51	16G121★	STRAINER	1
52‡	16F878	TUBE, PVC, LD pump (models 24G579, 24G591)	1
	16F948	TUBE, PVC, LD pump (models 24G580, 24G592)	1
	16F949	TUBE, PVC, LD pump (models 24G581, 24G593)	1
53‡	16F886	TUBE, metal, LD pump (models 24G582, 24G594)	1
	16F950	TUBE, metal, LD pump (models 24G583, 24G595)	1
	16F951	TUBE, metal, LD pump (models 24G584, 24G596)	1
54‡	16F885	TUBE, metal, LD pump (models 24G585, 24G597)	1
	16F962	TUBE, metal, LD pump (models 24G586, 24G598)	1
	16F963	TUBE, metal, LD pump (models 24G587, 24G599)	1
55	✕	O-Ring (not shown)	1

▲ Replacement Danger and Warning labels, tags, and cards are available at no cost.

‡ Packaged separately with universal pump.

⊗ Included in kit 24H853

✓ Included in kits 24K293 - 3:1; 24H855 - 5:1

★ Included in kits 24H611 (npt), 24J430 (bspp) 24J431 (bspt)

❖ Included in kit 24H798

† Included in kit 24H851

✕ Included in kit 24H848 (npt), 24H849 (bspp), 24H850 (bspt)

◆ Included in kit 24J757 (npt), 24J758 (bspp), 24J759 (bspt)

✕ Included in kit 24H749

## Related Oil Pump Kits

Kit No.	Description	Qty
24H611	KIT, repair, intake valve, npt, includes 11, 15, 28, 35, 51	1
24J430	KIT, repair, intake valve, bspp, includes 11, 15, 28, 35, 51	1
24J431	KIT, repair, intake valve, bspt, includes 11, 15, 28, 35, 51	1

### O-Ring Replacement Kit - 24K293 for 3:1 pumps; 24H855 for 5:1 pumps (FIG. 11)

**NOTE:** When replacing seals in the pump lower also service the throat and piston seals. Order repair kit 24H853. Instructions related to this kit are included in instruction manual 3A1494 (included with the kit).

Ref.	Description	Qty.
13	O-RING	1
14	O-RING	1
15	O-RING	1

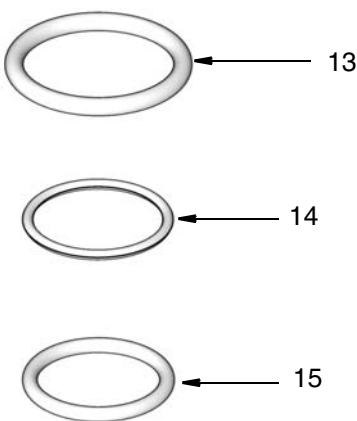

FIG. 11

### Throat and Piston Seal Replacement Kit - 24H853 (FIG. 12)

**NOTE:** When servicing the throat and piston seals, it is recommended to also replace seals in the pump lower. Order repair kit: 24K293 for 3:1 pumps or 24H855 for 5:1 pumps. Instructions related to this kits are included in instruction manual 3A1494 (included with the kit).

Ref.	Description	Qty.
5	O-RING, air piston	1
6	O-RING	1
7	O-RING	1
8	O-RING, wiper	1
9	SEAL, u-cup	1
17	O-RING	3
25	GASKET, cover, small	2
55	O-RING (not shown)	1

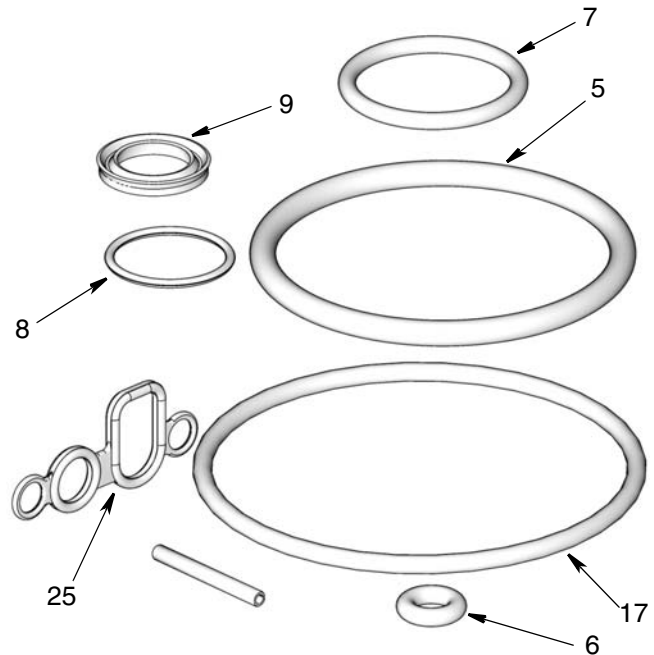
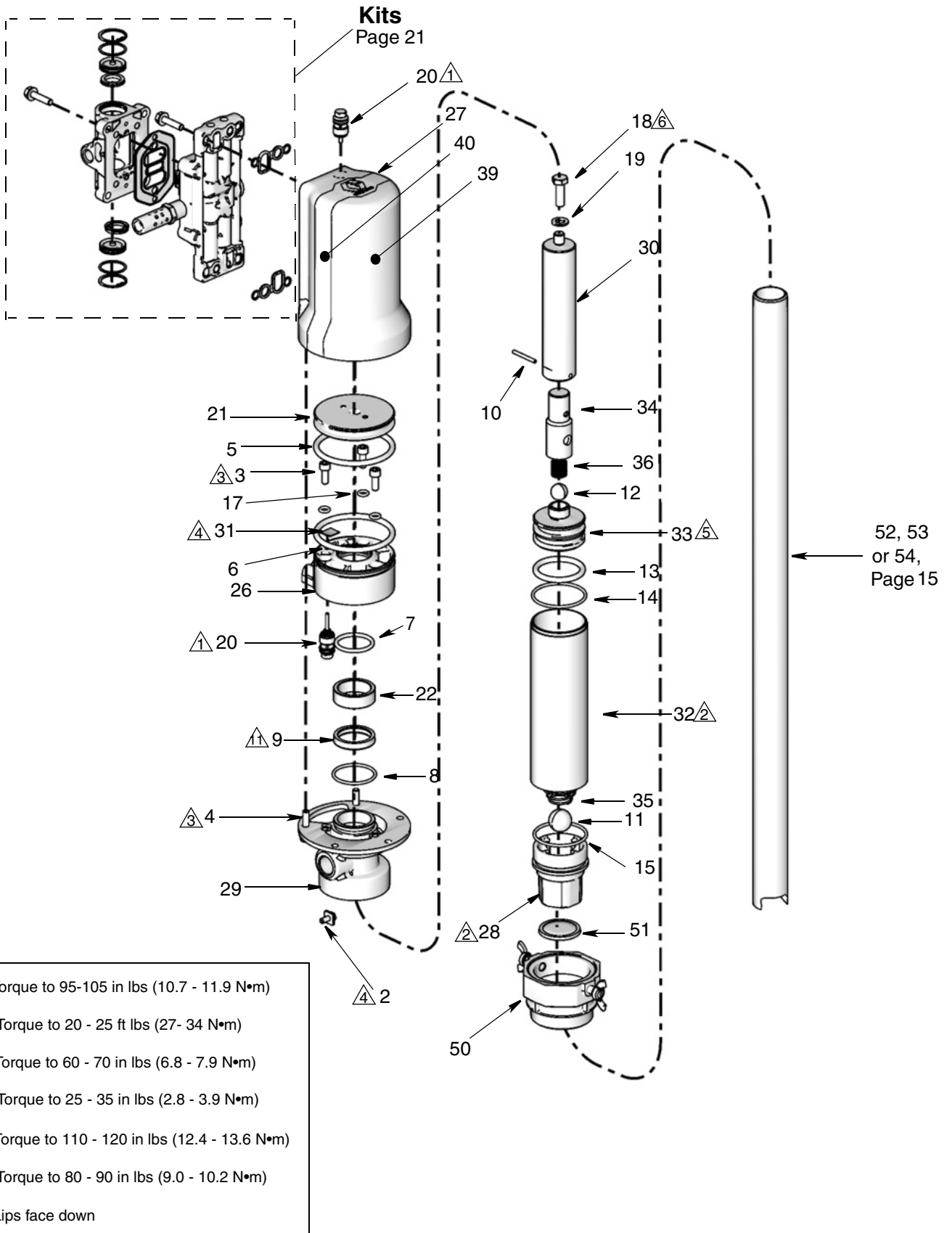

FIG. 12





## 50:1 Grease Pump Models: 24G600 - 24G608

Ref	Part No.	Description	Qty
2	116343	SCREW, ground	1
3		SCREW	3
4		SCREW, M6 X 22 mm	5
5	+	O-RING, air piston	1
6	+	O-RING (not shown)	1
7	+	O-RING	10
8	+@	PIN, straight, slotted, 2.5x16	3
9		SCREW	1
10	@	O-RING	1
11	+	SEAL, u-cup	1
12	+	O-RING	3
13		WASHER,M8	1
14		COVER, bottom, machining	1
15		PISTON, air, plastic	1
16	15M182 ‡ † ❁ ❂	SEAL, air valve, manifold	1
17	15M213	MUFFLER, 3/8	1
	112933	MUFFLER, quiet (optional)	1
18	+	GASKET, cover, small	2
19		NUT, hex	2
20	❂ ❁	VALVE, pilot	2
21		CYLINDER, air, machined	1
22		FLANGE, bottom cover, grease,	1
23		ROD, piston, 50:1	1
24	@	SEAL, piston	1
25		ROD, displacement, 50:1	1
26		CYLINDER, HP 50:1	1
27	24J380	KIT, cylinder, shovel	1
28	@	SEAL, intake	1
29		RETAINER, seal, al	1
30	+@	GASKET	2
31		BEARING, throat	1
32		ROD, connection	1
33		GUIDE, air	1

Ref	Part No.	Description	Qty
34		ROD, priming	1
35		PISTON, shovel, 50:1	1
36		CYLINDER, spacer	1
37	+	NUT, retainer	1
38		WASHER, 30 OD	1
39		HOUSING, manifold, machined	1
40	❁ ❂	VALVE, air, small	1
41	▲ 1GH013	LABEL, identification, LD 50:1	1
42	▲ 16G243	LABEL, safety, warning, multiple	1
43	❁	SCREW, M6 x 25 mm	8

▲ Replacement Danger and Warning labels, tags, and cards are available at no cost.

+ Included in kit 24H854

@ Included in kits 24H856

★ Included in kits 24H611 (npt), 24J430 (bspp) 24J431 (bspt)

❁ Included in kit 24H798

‡ Included in kit 24H851

❁ Included in kit 24H848 (npt), 24H849 (bspp), 24H850 (bspt)

❂ Included in kit 24J757 (npt), 24J758 (bspp), 24J759 (bspt)

❁ Included in kit 24H749

# Related Grease Pump Kits

## Throat and Piston Seal Replacement Kit - 24H854 (FIG. 13)

Instructions related to this kit are included in instruction manual 3A1495 (included with the kit).

Ref.	Description	Qty.
5	O-RING, air piston	1
6	O-RING	1
7	O-RING	1
8	PIN, slotted, straight	3
11	SEAL, u-cup	1
12	O-RING	3
18	GASKET, cover, small	2
30	GASKET	1
37	NUT, retainer	1

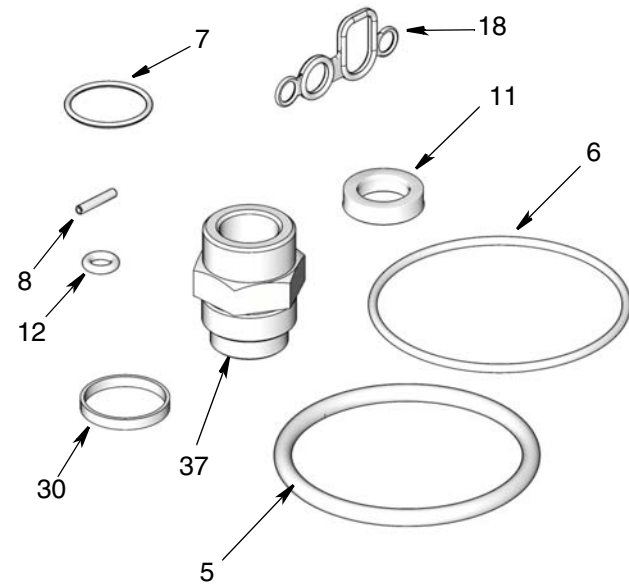

FIG. 13

## O-Ring and Seal Replacement Kit - 24H856 (FIG. 14)

Instructions related to this kit are included in instruction manual 3A1495 (included with the kit).

Ref.	Description	Qty.
8	PIN, slotted, straight	3
10	O-RING	1
24	SEAL, piston	1
28	SEAL, intake	1
30	GASKET	2

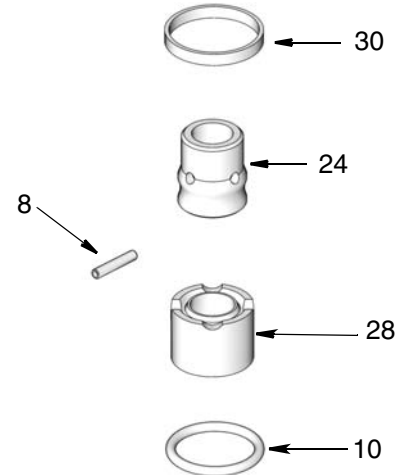
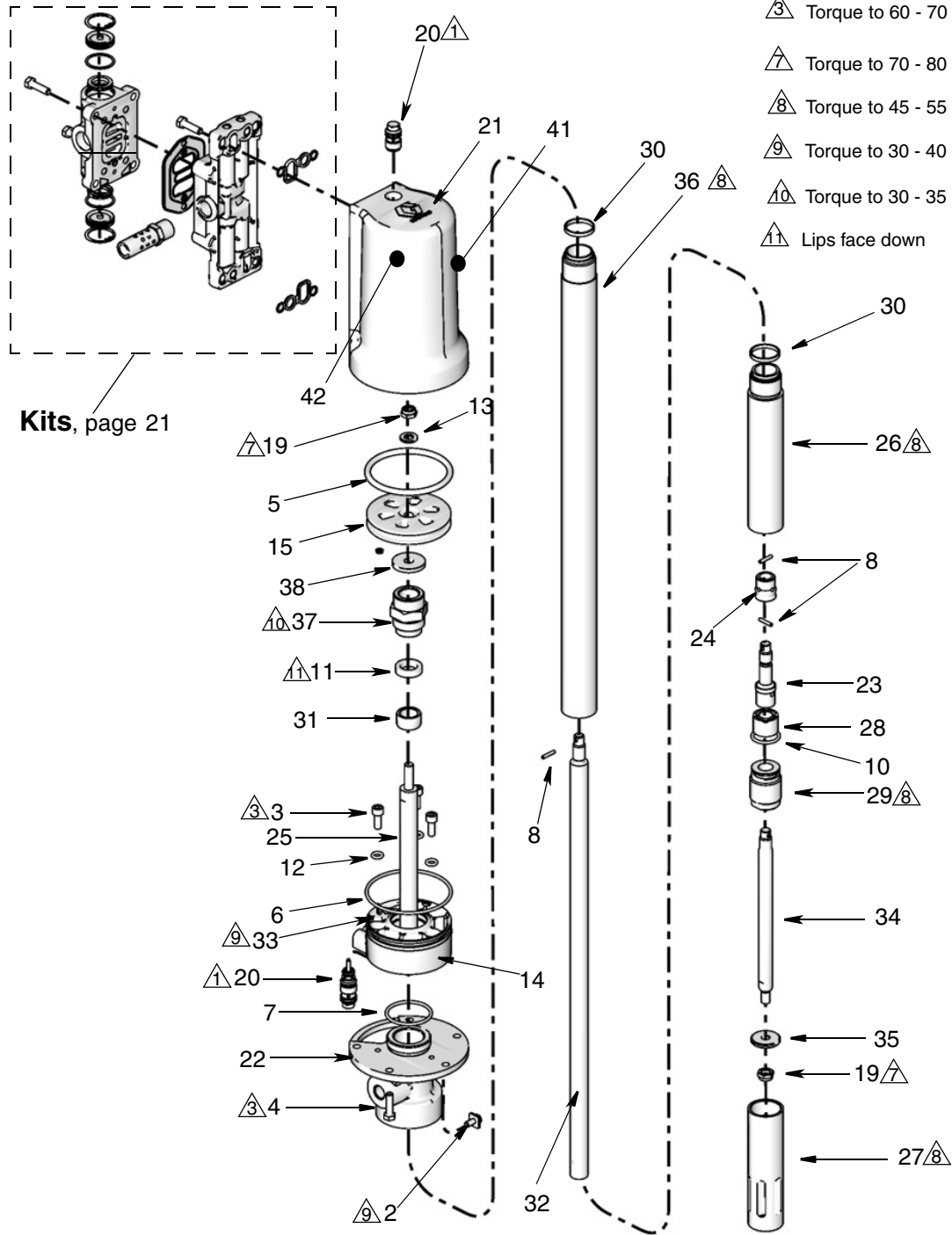

FIG. 14



△1 Torque to 95-105 in lbs (10.7 - 11.9 N•m)

△3 Torque to 60 - 70 in lbs (6.8 - 7.9 N•m)

△7 Torque to 70 - 80 in lbs (7.9 - 9.0 N•m)

△8 Torque to 45 - 55 ft lbs (61 - 75 N•m)

△9 Torque to 30 - 40 in lbs (3.4 - 4.5 N•m)

△10 Torque to 30 - 35 in lbs (3.4 - 4.0 N•m)

△11 Lips face down

Kits, page 21

# Oil or Grease Pump Air Valve Repair and Replacement Kits

Instructions related to the following kits are included in instruction manual 3A1496 (included with the kit).

## Replace Seals or Rebuild Air Valve Kits

**Air Valve Repair Kit - 24H798, Air Valve Seal Kit - 24H851 and Air Valve End Cap - 24H852.**

### Air Valve Repair Kit - 24H798

Ref.		Description	Qty.
Oil	Grease		
23	16	SEAL, air valve, manifold	1
381	381	O-RING, 018 buna	2
382	382	SEAL, u-cup, bevel lip	2
383	383	SCREW, M3, thread forming	2
386	386	PISTON, air valve	1
387	387	ROLLER, assembly, detent	1
388	388	PLATE, air valve	1
389	389	SPRING, detent, small	1
390	390	CUP, air valve, small	1
391	391	CAM, detent, small	1

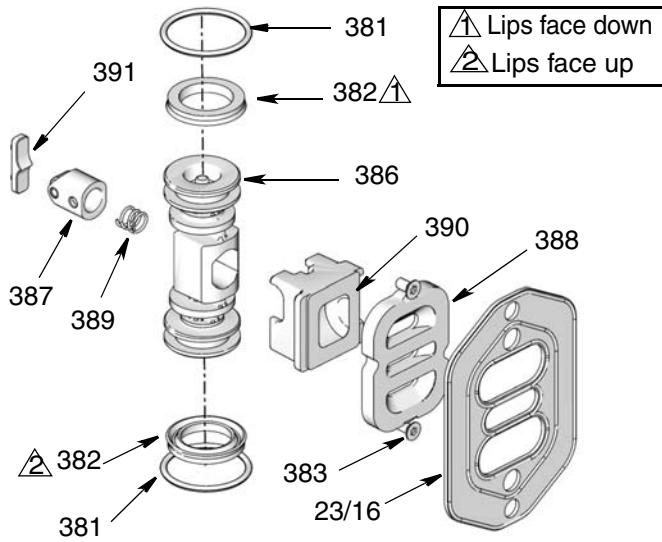

FIG. 15

### Air Valve Seal Kit - 24H851

Ref.		Description	Qty.
Oil	Grease		
23	16	SEAL, air valve, manifold	1
381	381	O-RING, 018 buna	2
382	382	SEAL, u-cup, bevel lip	2
383	383	SCREW, M3, thread forming	2

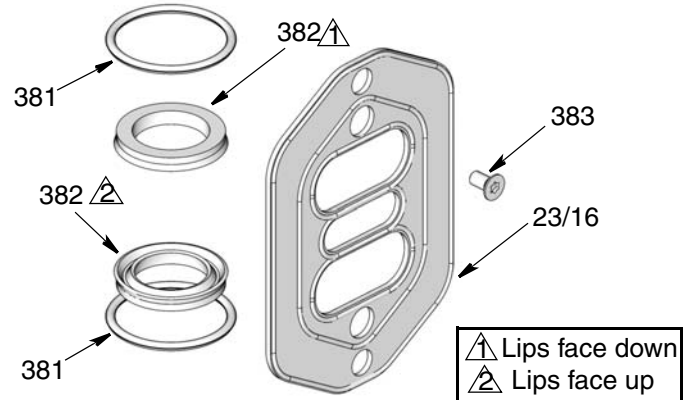

FIG. 16

### Air Valve End Cap Kit - 24H852

Ref.	Description	Qty.
381	O-RING, 018 buna	2
384	PLUG, air valve	2
385	RING, snap	2

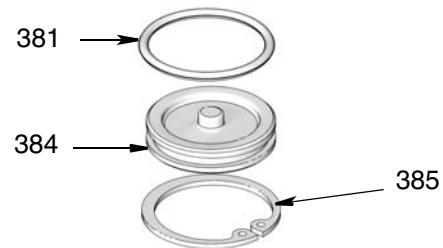
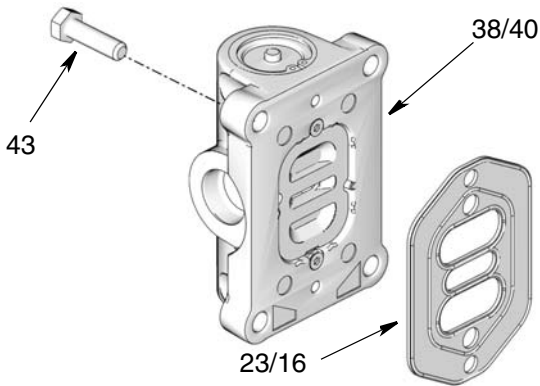

FIG. 17

**Air Valve Replacement Kit - 24H848 (npt), 24H849 (bspp), 24H850 (bspt) (FIG. 18)**



**FIG. 18**

Ref.		Description	Qty.
Oil	Grease		
23	16	SEAL, air valve	1
38	40	VALVE, air, small	1
43	43	SCREW, M6 x 25	4

**Pilot Valve Replacement Kit - 24H749**

*This kit only includes the pilot valves (20). If you also are repairing/replacing the air valve (38/40) and air valve seal (23/16) order the Air Motor Service Kit - 24J757 (npt), 24J758 (bspp) or 24J759 (bspt).*

Ref.	Description	Qty.
20	VALVE, pilot	2

**Air Motor Service Kit - 24J757 (npt), 24J758 (bspp), 24J759 (bspt) (FIG. 19)**

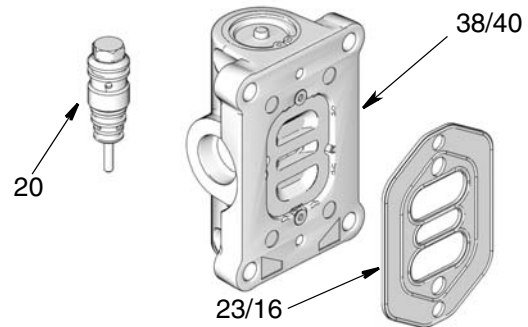

**FIG. 19**

Ref.		Description	Qty.
Oil	Grease		
20	20	VALVE, pilot	2
23	16	SEAL, air valve	1
40	40	VALVE, air, small	1

# Troubleshooting

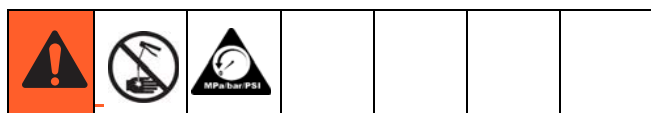

**NOTE:** Check all other possible problems and solutions before disassembling the pump. Before you troubleshoot problems using the table below, **relieve the pressure** and disconnect the pump fluid line. If the pump starts when the air is turned on again, the fluid line, dispensing valve, etc. clogged.

## Oil Models

Problem	Cause	Solution
Pump runs but no fluid output	Pump is not fully primed	Crack a fitting at the outlet of the pump to allow a slow leak to purge any air in the pump. Repeat start up procedure, page 11.
	Oil leakage	Check connection and tighten.
	The piston valve is not seating properly or the piston o-ring is damaged	Check and replace parts as needed.
	Exhausted fluid supply	Refill and reprime.
	The pump inlet filter is blocked	Clear the filter
	The suction tube (hose) has an air leak	Check the connection and tighten as needed.
Pump fails to operate or stops	Damaged pilot valve	Service pilot valve.
		Lower air pressure to prevent reoccurrence.
	Damaged main air valve	Replace air valve.
		Lower air pressure to prevent reoccurrence.
	Inadequate air supply pressure or restricted air lines.	Increase air supply; clear.
	Closed or clogged dispensing valve	Open valve if closed. Clear clog if necessary.
Clogged fluid lines, hose valves, etc.	Clear clogs.	
Erratic or accelerated operation	Exhausted fluid supply	Refill and reprime.
	Damaged valve gasket	Replace valve gasket.
		Lower air pressure to prevent reoccurrence.

Problem	Cause	Solution
Intermittent air leakage coming from behind the air manifold. Pump continues to function normally.	Gasket is leaking	Replace gasket.
		Lower air pressure to prevent reoccurrence.
	Thermal relief inlet check relief passage in inlet housing is plugged	Clear obstruction.
		Replace inlet filter.
Continuous air exhaust	Worn or damaged piston o-ring or valve cup.	Service air motor / valve
	Damaged valve gasket	Replace valve gasket.
		Lower air pressure to prevent reoccurrence.
Pump operates but output is low	Held open or worn intake valve	Clear; service.
	Held open or worn pump piston packings	Clear; service.
	The muffler is partially blocked	Clear muffler.
	The inlet filter is partially blocked	Clear the filter.
	Inadequate air supply pressure or restricted air lines	Increase air supply; clear restrictions.
	Partially closed or clogged pilot valves	Open valves. Clear clog as necessary.
	Partially clogged fluid line, hose, valves, etc.	Clear clog as necessary.
Oil leakage through air exhausts	Throat seal is damaged	Replace throat seal (u-cup).



## Grease Models

Pump fails to operate	Inadequate air supply pressure or restricted air lines	Increase air supply and/or clear restriction.
	Closed or clogged pump valves	Open and/or clean.
	Clogged fluid line, hose, valve, or other accessory	<b>Relieve pressure.</b> Clear obstruction.
	Damaged air motor	Assess damage, and service air motor.
	Exhausted fluid supply	Refill and reprime or flush.
Continuous air exhaust	Worn or damaged piston o-ring or valve cup	Assess wear or damage, and service air motor.
Erratic pump operation	Exhausted fluid supply	Refill and reprime or flush.
	Worn pump seals	Replace.
	Damaged shovel tube	Replace.
	Damaged check seat	Replace pump piston or shovel rod (or other damaged part).
Erratic or accelerated pump speed	Exhausted fluid supply	Refill and reprime or flush.
	Fluid too heavy for pump priming	Use inductor or follow plate.
	Damaged valve gasket	Replace valve gasket.
Lower air pressure to prevent recurrence.		
Pump operates but output is low	Worn piston seal	Replace.
	Damaged upper check seat	Replace pump piston.
	Worn fluid intake seal	Replace.
	Damaged lower check seat	Replace shovel rod.
	Inadequate air supply pressure or restricted air lines	Increase air supply and/or clear restriction.
	Partially closed or clogged pump valves	Open and/or clean.
	Air pockets in the grease inlet	Eliminate the air pockets.
	Partially clogged fluid line, hose, valve, or other accessory	<b>Relieve pressure.</b> Clear obstruction.
Worn seals	Replace.	
Grease leaking from muffler	Worn throat seal	Replace.

# Technical Data

## 3:1 or 5:1 Oil Models

Maximum fluid working pressure	750 psi (51.7 bar, 5.17 MPa)
Fluid pressure ratio	3:1 or 5:1
Suction lift (feet of oil)	10
Air operation range	20 to 150 psi (1.37 to 10.3 bar; 0.137 to 1.03 MPa)
Recommended air pressure for optimum pump life	<125 psi (8.6 bar, 0.86 MPa)
Air consumption (at 100 psi)	See Performance Curves, page 29
Cycles per gallon/(liter)	3:1 - 29 cycles per gallon (7 cycles per liter); 5:1 - 37 cycles per gallon (10 cycles per liter)
Maximum recommended pump speed	3:1 - 120 cycles per minute; 5:1 - 180 cycles per minutes
Recommended speed for optimum pump life	75 cycles per minute and lower 3:1 - 2.6 gallons per minute (9.8 liters per minute); 5:1 - 2 gallons per minute (7.6 liters per minute)
Wetted parts	zinc plated carbon, steel, aluminum, nitrile, polyurethane, nickel plated aluminum
Sound pressure level†*	72.9 dB(a)
Sound power level‡*	82.0 dB(a)
Performance curve	See charts page 28
Approximate weight	3:1 - 7 pounds (3.2 kg); 5:1 - 7.7 pounds (3.5 kg)
Dimensions	See page 30

† Calculated at a distance of 1 meter from measurements taken per ISO 9614-2 @ 100 psi air pressure (6.89 bar, 0.68 MPa) and 20 cycles per minutes.

‡ Measured per ISO 9614-2 at 100 psi air pressure (6.89 bar, 0.68 MPa) and 20 cycles per minute.

\* Muffler 112933 can be ordered separately for reduced sound levels.

**Dimensions**

Model	L inches (mm)	O (Overall Length) inches (mm)
Universal Pump Only	6.9 (175)	16 (406)
Multi*	42.4 (1076)	51.5 (1307)
Drum	35.7 (907)	44.8 (1138)
Tote	42.8 (1087)	51.9 (1318)

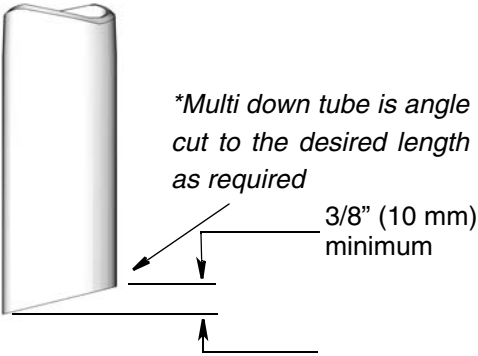

Universal Pump

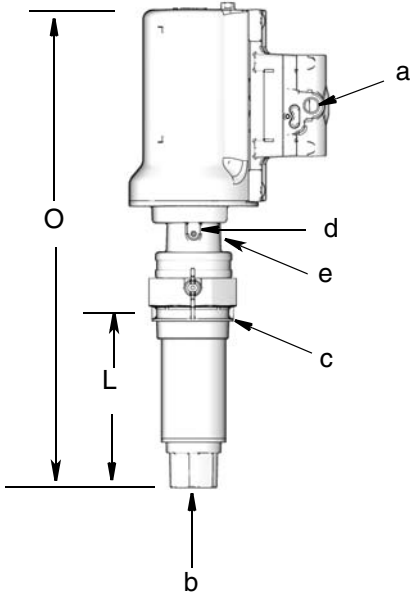

Multi/Drum/Tote

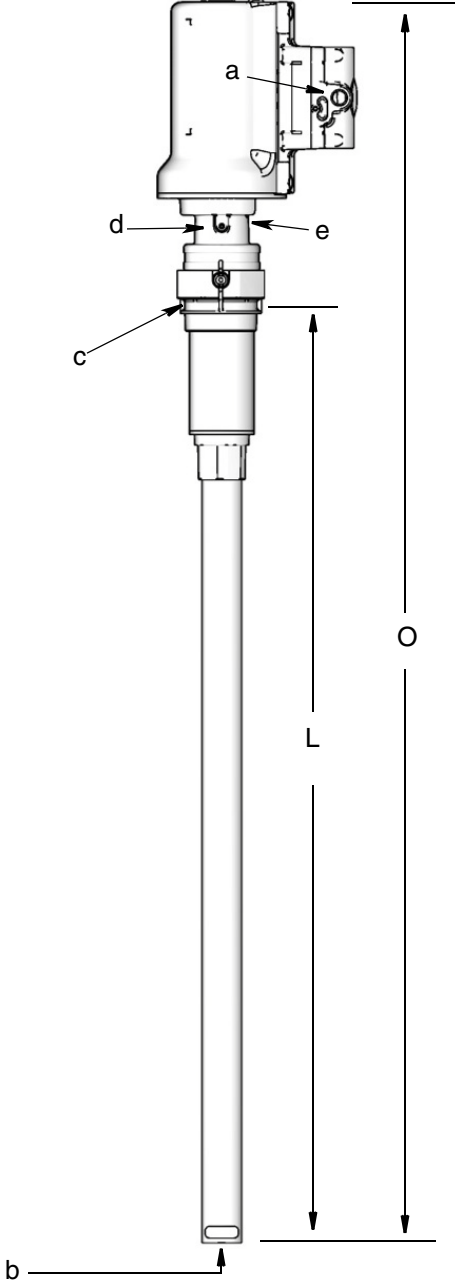

- a = 1/4 inch air inlet
- b = 1 inch fluid inlet
- c = 2 inch npt bung adapter
- d = ground screw
- e = 1/2 inch fluid outlet - opposite of d

## Performance Curve

### 3:1 Oil Models

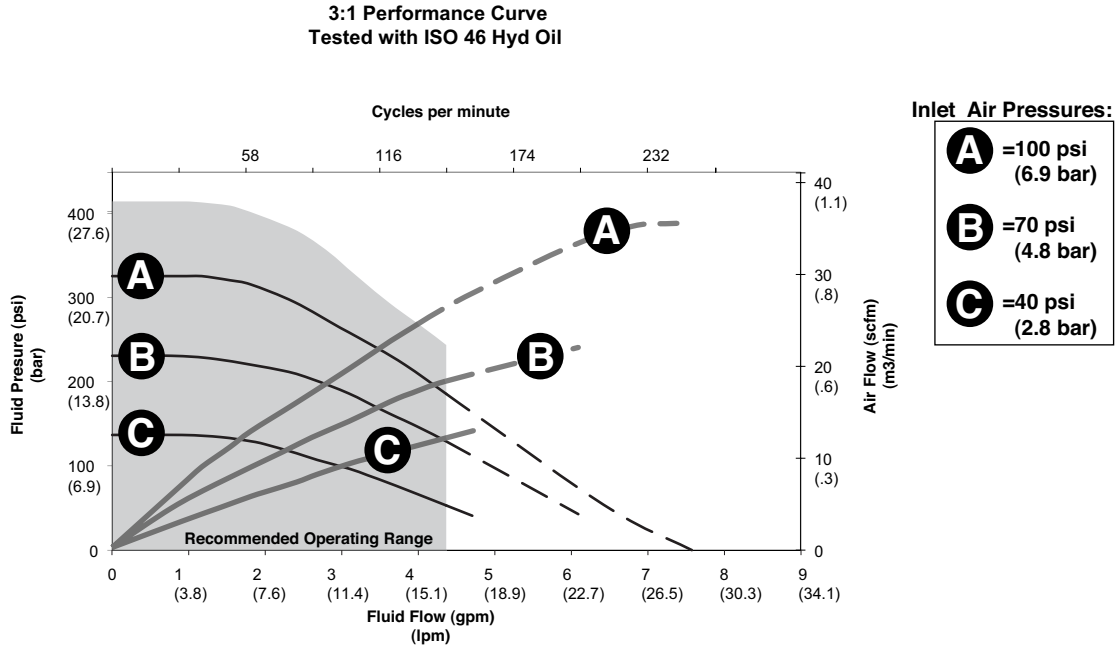

### 5:1 Oil Models

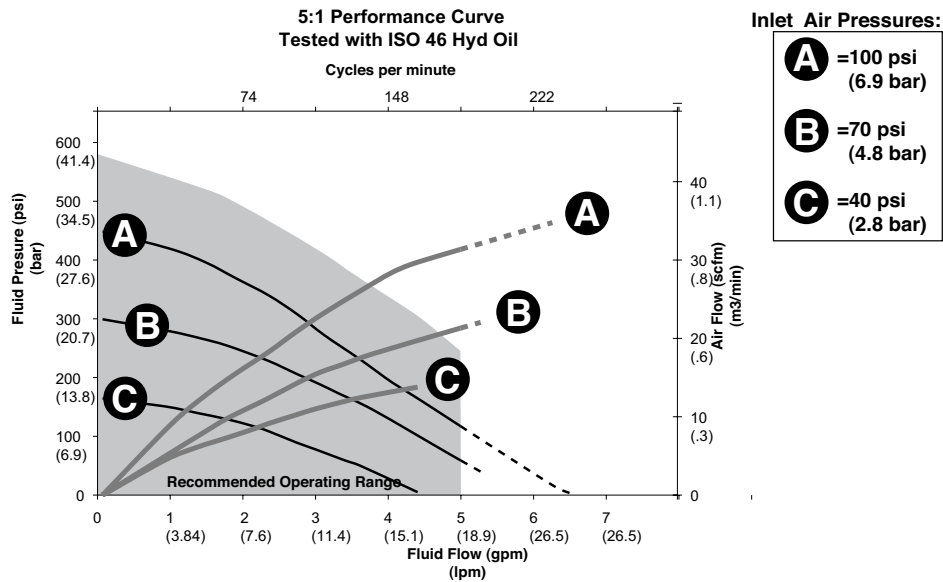

## 50:1 Grease Models

Maximum working pressure	7500 psi (517 bar, 51.7 MPa)
Fluid pressure ratio	50:1
Air operation range	20 to 150 psi (1.37 to 10.3 bar; 0.137 to 1.03 MPa)
Air consumption (at 100 psi)	See Performance Curve, page 30
Pump cycles per pound (cycles per kg)	47 cycle per pound (103 cycle per kg)
Maximum recommended pump speed	120 cycles per minute
Recommended speed for optimum pump life	60 cycles per minute or lower flow rate; 1.3 pounds per minute (0.6 kg per minute)
Wetted parts	steel, brass, nitrile rubber, polyurethane, UHMWPE, acetal
Sound pressure level†*	72.9 dB(a)
Sound power level‡*	82.0 dB(a)
Performance curve	See chart page 30
Approximate weight	35 pound drum - 11.2 pounds (5.1 kg); 120 pound drum - 15.0 pounds (6.8 kg); 400 pound drum - 170.0 pounds (7.7 kg)
Dimensions	See illustration below

† Calculated at a distance of 1 meter from measurements taken per ISO 9614-2 @ 100 psi air pressure (6.89 bar, 0.68 MPa) and 20 cycles per minutes.

‡ Measured per ISO 9614-2 at 100 psi air pressure (6.89 bar, 0.68 MPa) and 20 cycles per minute.

\* Muffler 112933 can be ordered separately for reduced sound levels.

## Performance Curve

### Grease Models

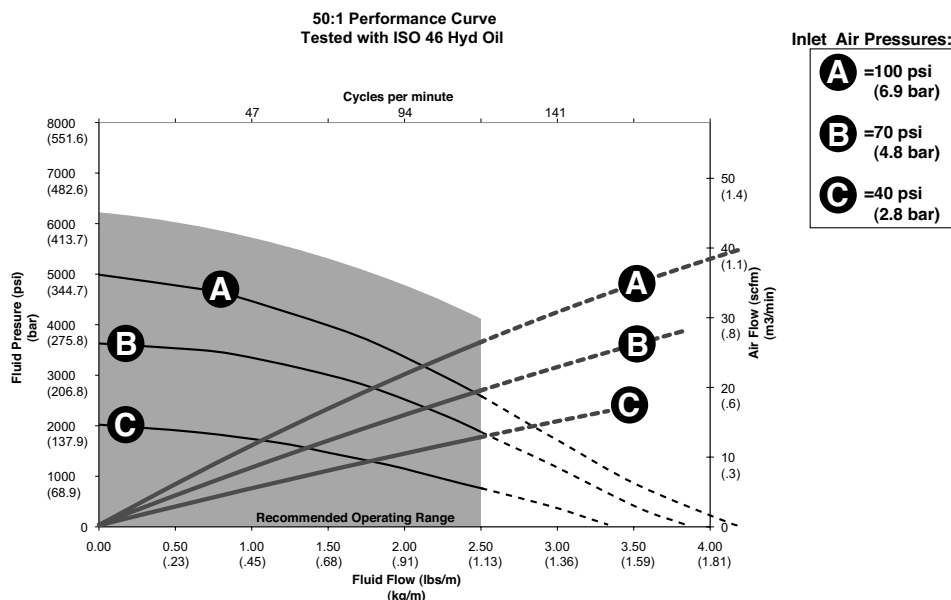

## Dimensions

- a = 1/4 inch air inlet
- b = 1/4 inch fluid outlet
- c = 2 inch npt mounting configuration
- d = ground screw

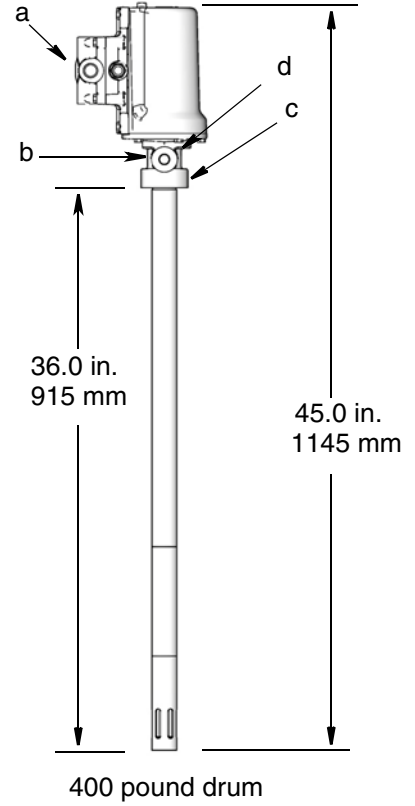
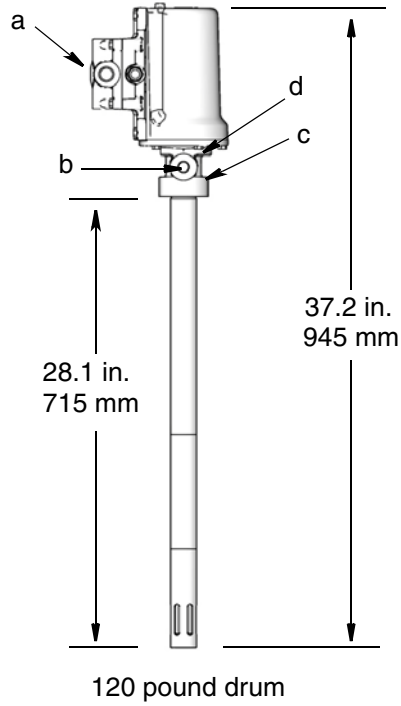
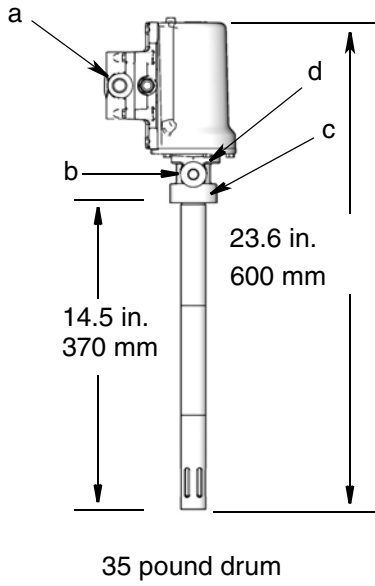



# Graco Standard Warranty

Graco warrants all equipment referenced in this document which is manufactured by Graco and bearing its name to be free from defects in material and workmanship on the date of sale to the original purchaser for use. With the exception of any special, extended, or limited warranty published by Graco, Graco will, for a period of twelve months from the date of sale, repair or replace any part of the equipment determined by Graco to be defective. This warranty applies only when the equipment is installed, operated and maintained in accordance with Graco's written recommendations.

This warranty does not cover, and Graco shall not be liable for general wear and tear, or any malfunction, damage or wear caused by faulty installation, misapplication, abrasion, corrosion, inadequate or improper maintenance, negligence, accident, tampering, or substitution of non-Graco component parts. Nor shall Graco be liable for malfunction, damage or wear caused by the incompatibility of Graco equipment with structures, accessories, equipment or materials not supplied by Graco, or the improper design, manufacture, installation, operation or maintenance of structures, accessories, equipment or materials not supplied by Graco.

This warranty is conditioned upon the prepaid return of the equipment claimed to be defective to an authorized Graco distributor for verification of the claimed defect. If the claimed defect is verified, Graco will repair or replace free of charge any defective parts. The equipment will be returned to the original purchaser transportation prepaid. If inspection of the equipment does not disclose any defect in material or workmanship, repairs will be made at a reasonable charge, which charges may include the costs of parts, labor, and transportation.

**THIS WARRANTY IS EXCLUSIVE, AND IS IN LIEU OF ANY OTHER WARRANTIES, EXPRESS OR IMPLIED, INCLUDING BUT NOT LIMITED TO WARRANTY OF MERCHANTABILITY OR WARRANTY OF FITNESS FOR A PARTICULAR PURPOSE.**

Graco's sole obligation and buyer's sole remedy for any breach of warranty shall be as set forth above. The buyer agrees that no other remedy (including, but not limited to, incidental or consequential damages for lost profits, lost sales, injury to person or property, or any other incidental or consequential loss) shall be available. Any action for breach of warranty must be brought within two (2) years of the date of sale.

**GRACO MAKES NO WARRANTY, AND DISCLAIMS ALL IMPLIED WARRANTIES OF MERCHANTABILITY AND FITNESS FOR A PARTICULAR PURPOSE, IN CONNECTION WITH ACCESSORIES, EQUIPMENT, MATERIALS OR COMPONENTS SOLD BUT NOT MANUFACTURED BY GRACO.** These items sold, but not manufactured by Graco (such as electric motors, switches, hose, etc.), are subject to the warranty, if any, of their manufacturer. Graco will provide purchaser with reasonable assistance in making any claim for breach of these warranties.

In no event will Graco be liable for indirect, incidental, special or consequential damages resulting from Graco supplying equipment hereunder, or the furnishing, performance, or use of any products or other goods sold hereto, whether due to a breach of contract, breach of warranty, the negligence of Graco, or otherwise.

## **FOR GRACO CANADA CUSTOMERS**

The Parties acknowledge that they have required that the present document, as well as all documents, notices and legal proceedings entered into, given or instituted pursuant hereto or relating directly or indirectly hereto, be drawn up in English. Les parties reconnaissent avoir convenu que la rédaction du présente document sera en Anglais, ainsi que tous documents, avis et procédures judiciaires exécutés, donnés ou intentés, à la suite de ou en rapport, directement ou indirectement, avec les procédures concernées.

## Graco Information

For the latest information about Graco products, visit [www.graco.com](http://www.graco.com).

**TO PLACE AN ORDER**, contact your Graco distributor or call to identify the nearest distributor.

**Phone:** 612-623-6928 or **Toll Free:** 1-800-533-9655, **Fax:** 612-378-3590

*All written and visual data contained in this document reflects the latest product information available at the time of publication. Graco reserves the right to make changes at any time without notice.*

Original instructions. This manual contains English. MM 3A1334

For patent information, see [www.graco.com/patents](http://www.graco.com/patents).

Graco Headquarters: Minneapolis

**International Offices:** Belgium, China, Japan, Korea

**GRACO INC. P.O. BOX 1441 MINNEAPOLIS, MN 55440-1441**

**Copyright 2011, Graco Inc. is registered to ISO 9001**

[www.graco.com](http://www.graco.com)

4/2011, revised March 2012